

Adjustments

⚠ Warning!

Before driving, always make sure that the basic settings made by Öhlins are according to recommended Set-up Data. Read about adjustments and setting up in the Öhlins Owner's Manual before you make any adjustments. Contact an Öhlins dealer if you have any questions about setting up the shock absorber.

The standard preload is 2 mm from a free length of 200 mm, giving 198 mm installed length, see fig ③.

Set-up Data

Recommended set-up

Rebound 10 clicks
Spring preload 2 mm
Shock absorber length 605 mm

Spring

Spec H200, ID65, 100N/mm

The actual vehicle height

With both the preload and height adjustments in their standard positions, the vehicle is lowered approximately 20 mm when compared to the original suspension. As the height adjuster is turned one rotation, the position moves 1.5 mm.

⚠ Warning!

The adjustment range is the standard position ± 15 mm. If the bracket is moved outside the adjustment range, it may come loose.

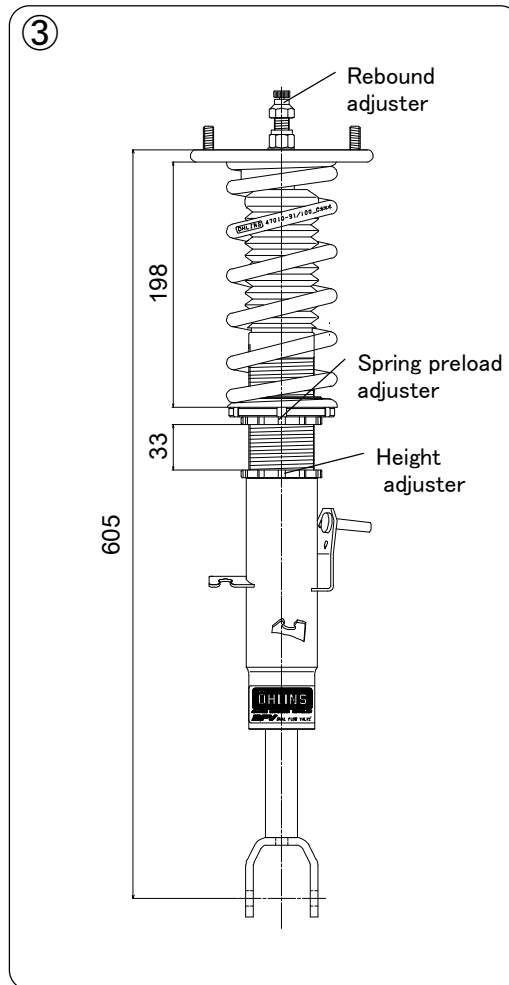

Before installing this product, check the contents of the kit. If anything is missing, please contact an Öhlins dealer.

Kit Contents	Pcs.
Shock absorber	2
Dust boot	2
Top mount	2
Spring	2
Nylon nut M12	2

MOUNTED ON SHOCK ABSORBER
Adjuster 2

USED FOR BOTH FRONT AND REAR

C-spanner	1
C-spanner	1
Öhlins sticker	1
Öhlins Owner's Manual	1

Please note that during storage and transportation, especially at high ambient temperature, some of the oil and grease used for assembling may leak and stain the packaging. This is in no way detrimental to the product, wipe off the excess oil/grease with a cloth.

⚠ Warning!

Before installing this product, read the Öhlins Owner's Manual. The shock absorber is an important part of your vehicle and will affect the stability.

Öhlins products are subject to continuous improvement and development, therefore, although these instructions include the most up-to-date information available at the time of printing, minor updates may occur.

To find the latest information contact your Öhlins distributor. Please consult your Öhlins dealer if you have any questions regarding the contents in this document.

Part no. NISM100_0
Issued 2010-01-30



Shock Absorber Kit for Nissan 350Z (Z33)

NIS M100 front

Mounting Instructions

© Öhlins Racing AB. All rights reserved. Any reprinting or unauthorized use without the written permission of Öhlins Racing AB is prohibited.

Öhlins Racing AB



www.ohlins.com



⚠ Warning!

It is advisable to have an Öhlins dealer install the shock absorber.
When installing, read your Vehicle Service Manual.

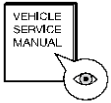

1
Raise the vehicle and put it on jack stands.

⚠ Warning!

Ensure that it is securely supported.

- 2**
Remove the front wheels.
- 3**
Remove the lower and the upper attachments and remove the original shock absorbers.
- 4**
Cut the dust boot 52 mm from the lower end with a pair of scissors according to fig ②.
- 5**
Tighten the lower spring seat and the lock nut to 50 - 60 Nm.
Fit the the dust boot, the spring, the top mount and the adjuster according to fig ①. Tighten the nylon nut to 30 Nm.

👁 Note!

When tightening the top mount nut, the shock absorber shaft must be held in position with a flat screwdriver.

- 6**
Install the Öhlins shock absorbers on the vehicle.
- 7**
Fasten the upper attachments.

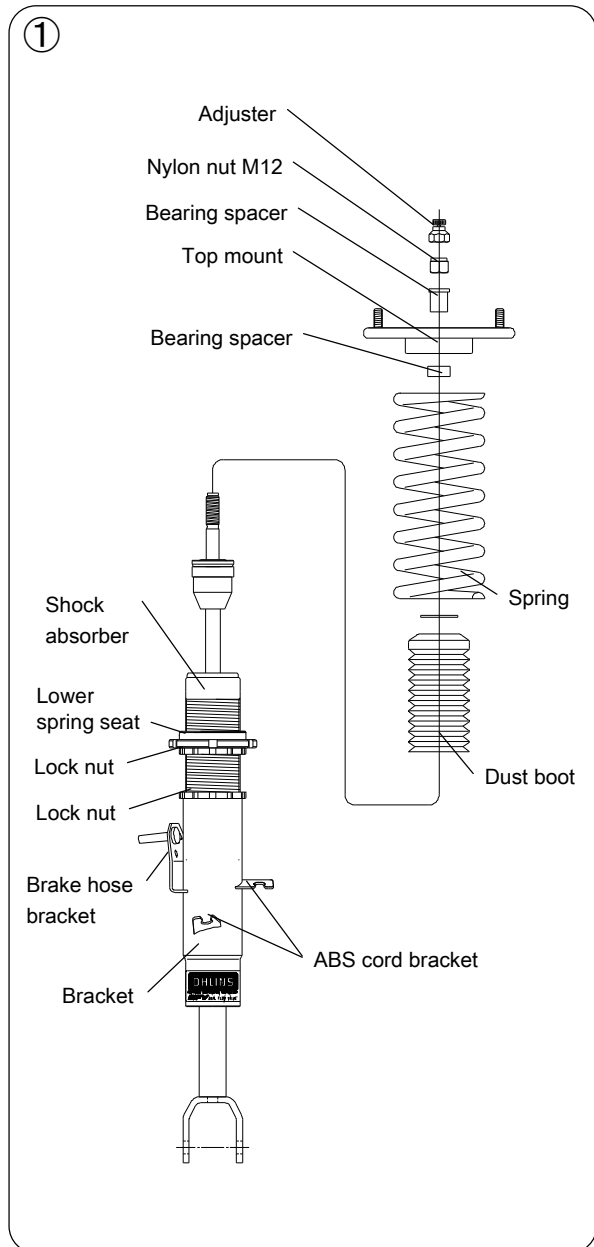

8
Mount the original brake hose and the original ABS cord to the Öhlins shock absorbers.

👁 Note!

Make sure that all bolts are tightened to the correct torque and that nothing fouls or restricts movement of the shock absorber when it is being fully compressed or extended.

9
Make sure that all removed parts are reinstalled in the same way as they were before the installation of the Öhlins shock absorber.

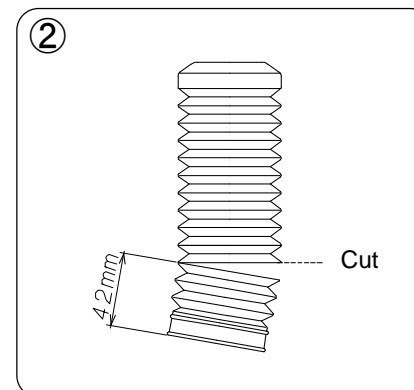

Adjustments

⚠ Warning!

Before driving, always make sure that the basic settings made by Öhlins are according to recommended Set-up Data. Read about adjustments and setting up in the Öhlins Owner's Manual before you make any adjustments. Contact an Öhlins dealer if you have any questions about setting up the shock absorber.

Set-up Data

Recommended set-up

Rebound 10 clicks

Spring height adjuster
44 mm (see fig ③)

Spring

Spec H240, ID98, 55~ 70 N/mm

The actual vehicle height

With height adjustments in their standard positions, the vehicle is lowered approximately 20 mm when compared to the original suspension. As the height adjuster is turned one rotation, the position moves 2.0 mm.

⚠ Warning!

The adjustment range is the standard position +15 to -10 mm. If the spring height adjuster is moved outside the adjustment range, it may come loose.

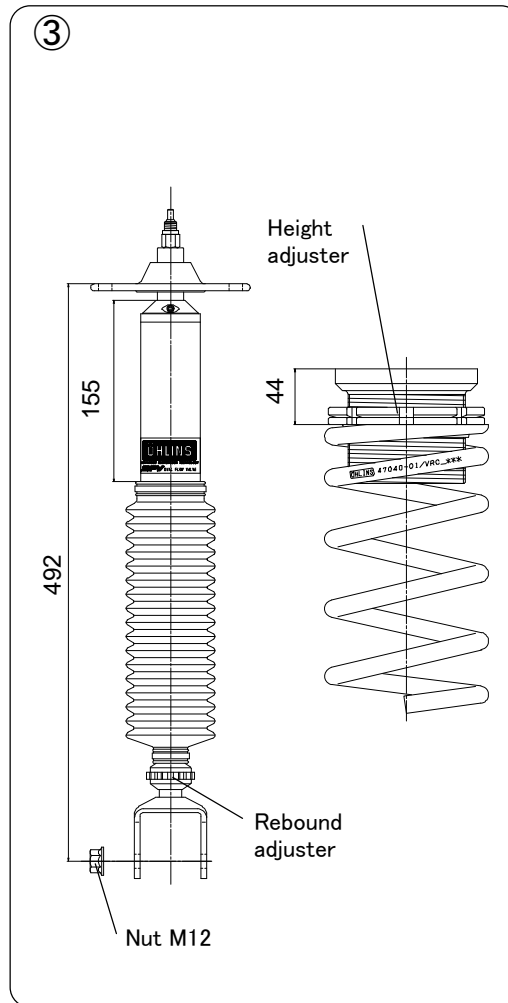

Before installing this product, check the contents of the kit. If anything is missing, please contact an Öhlins dealer.

Kit Contents	Pcs.
Shock absorber	2
Dust boot	2
Top mount	2
Nylon nut M10	2
Nut M12	2
Spring	2
Spring height adjuster	2
Tie-rod	4

USED FOR BOTH FRONT AND REAR

C-spanner	1
C-spanner	1
Öhlins sticker	1
Öhlins Owner's Manual	1

Please note that during storage and transportation, especially at high ambient temperature, some of the oil and grease used for assembling may leak and stain the packaging. This is in no way detrimental to the product, wipe off the excess oil/grease with a cloth.

⚠ Warning!

Before installing this product, read the Öhlins Owner's Manual. The shock absorber is an important part of your vehicle and will affect the stability.

Öhlins products are subject to continuous improvement and development, therefore, although these instructions include the most up-to-date information available at the time of printing, minor updates may occur.

To find the latest information contact your Öhlins distributor. Please consult your Öhlins dealer if you have any questions regarding the contents in this document.

Part no. NISM100_0
Issued 2010-01-30



Shock Absorber Kit for Nissan 350Z (Z33)

NIS M100 rear

Mounting Instructions

© Öhlins Racing AB. All rights reserved. Any reprinting or unauthorized use without the written permission of Öhlins Racing AB is prohibited.

Öhlins Racing AB



www.ohlins.com



How to install

⚠ Warning!

It is advisable to have an Öhlins dealer install the shock absorber.

When installing, read your Vehicle Service Manual.



1

Raise the vehicle and put it on jack stands.

⚠ Warning!

Ensure that it is securely supported.

2

Remove the rear wheels.

3

Remove the lower and the upper attachments and remove the original shock absorbers.

⚠ Caution!

Support the lower arm with the jack before removing the damper. Otherwise, when the damper is removed, the lower arm rapidly falls.

4

Remove the original spring.

5

Set the spring height adjuster to the position according to fig ②. It is set at the bottom when delivered.

6

Install the Öhlins spring and the spring height adjuster on the vehicle.

7

Mount the the dust boot on the Öhlins shock absorber according to fig ①. Tighten only the lower tie-rap. Fit the top mount on the shock absorber according to fig ①. Tighten the nylon nut to 20 Nm.

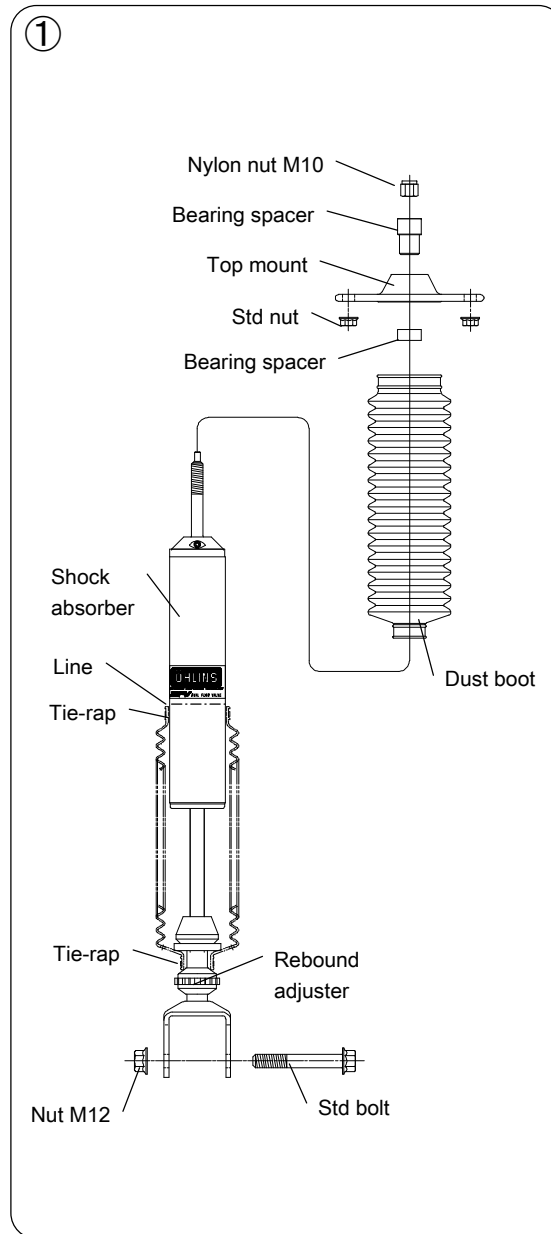

How to install

8

Install the Öhlins shock absorbers on the vehicle.

9

Position the top of the dust boot according to fig ①. Tighten the upper tie-rap.

👁 Note!

When tightening the top mount nut, the shock absorber shaft must be held in position with a 5 mm spanner.

Make sure that all bolts are tightened to the correct torque and that nothing fouls or restricts movement of the shock absorber when it is being fully compressed or extended.

10

Make sure that all removed parts are reinstalled in the same way as they were before the installation of the Öhlins shock absorber.

